

# FC2

## PROPRIETARY SYSTEM

### SISTEMA EXCLUSIVO



**Bold part number, product available**  
 Other part numbers please consult  
**Referencia en negrita producto disponible**  
 Otras referencias consúltenos

L	RC	SYL	U	VTL	WTS	TL	RPHD	RPL	HL2	SIZE
FC2-200 L	FC2-200 RC	FC2-200 SYL			FC2-200 WTS				FC200HL2	<b>20</b>
FC2-220 L									FC220HL2	<b>22</b>
FC2-250 L	FC2-250 RC		FC2-250 U					FC2-250 RPL	FC250HL2	<b>25</b>
FC2-300 L	FC2-300 RC	FC2-300 SYL	FC2-300 U		FC2-300 WTS			FC2-300 RPL	FC300HL2	<b>30</b>
FC2-350 L	FC2-350 RC	FC2-350 SYL	FC2-350 U		FC2-350 WTS			FC2-350 RPL	FC350HL2	<b>35</b>
FC2-400 L	FC2-400 RC							FC2-400 RPL	FC400HL2	<b>40</b>
FC2-450 L	FC2-450 RC	FC2-450 SYL	FC2-450 U	FC2-450 VTL	FC2-450 WTS			FC2-450 RPL	FC450HL2	<b>45</b>
FC2-550 L	FC2-550 RC		FC2-550 U	FC2-550 VTL				FC2-550 RPL	FC550HL2	<b>55</b>
FC2-600 L	FC2-600 RC		FC2-600 U	FC2-600 VTL				FC2-600 RPL	FC600HL2	<b>60</b>
				FC2-700 VTL			FC2-700 RPHD		FC700HL2	<b>70</b>
	FC2-800 RC			FC2-800 VTL		FC2-800 TL			FC800HL2	<b>80</b>

**NOSE COMPATIBILITY**  
**COMPATIBILIDAD DE LA NARIZ**

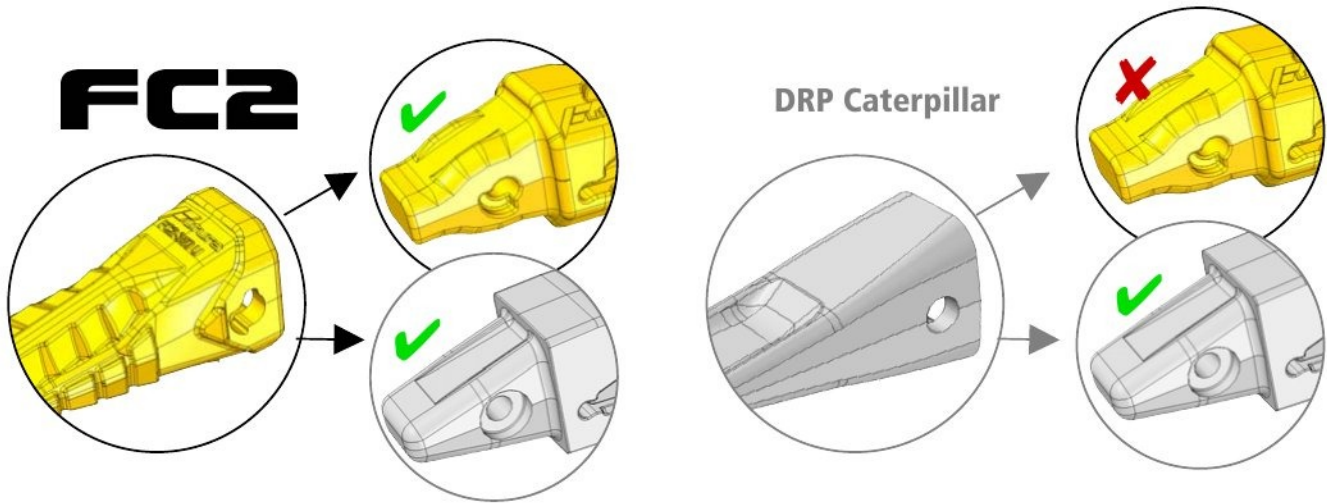

**LOCKING OPTIONS**  
**OPCIONES DE ANCLAJE**

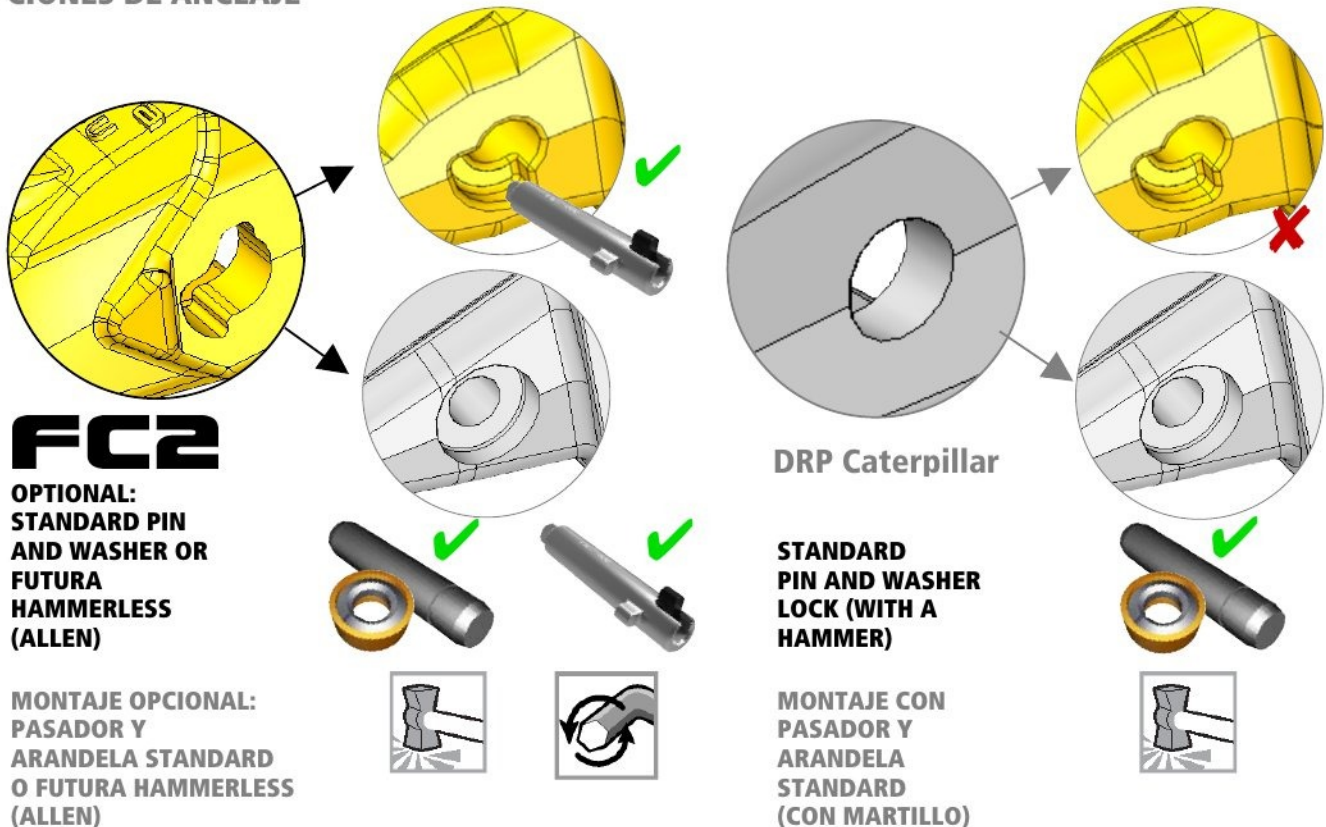

# PROPRIETARY SYSTEM SISTEMA EXCLUSIVO

# FC2

NEW 4-NERVE NOSE IMPROVES SIDE PIN FITMENT

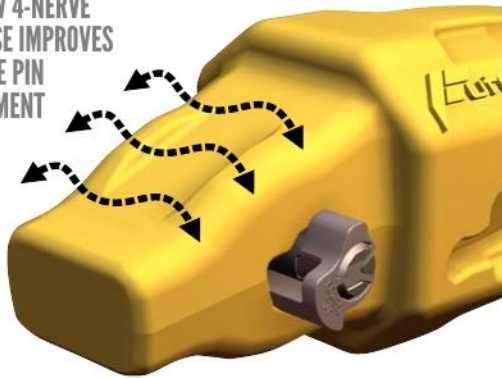

NEW 4-NERVE NOSE ADDS STABILITY

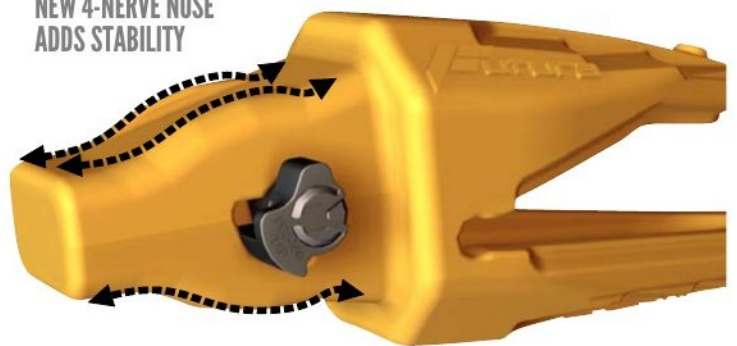

**1**  
BENEFIT

**ONE TOOTH  
FITS TWO  
SYSTEMS**

**1x2**  
COMPATIBILITY

FC2 teeth are fully compatible with standard J Series Adapters

**2**  
BENEFIT

**HAMMERLESS  
AND SAFE  
SYSTEM**



FC2 teeth are easily assembled and disassembled with a standard Allen or hex key.

**3**  
BENEFIT

**OUTSTANDING  
QUALITY &  
UNBEATABLE PRICE**

FC2 parts are sold at Futura Wear Technology prices. Stock savings: ONE tooth would fit onto TWO systems

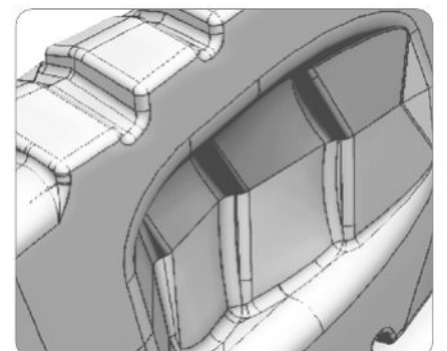
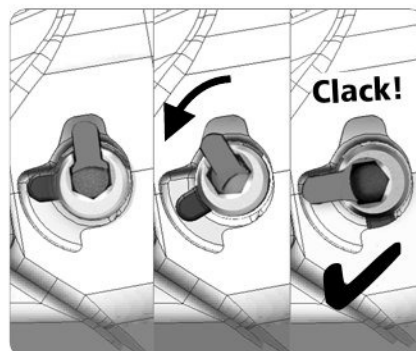

**Teeth ROCK PENETRATION HD Diente PENETRACIÓN HD**

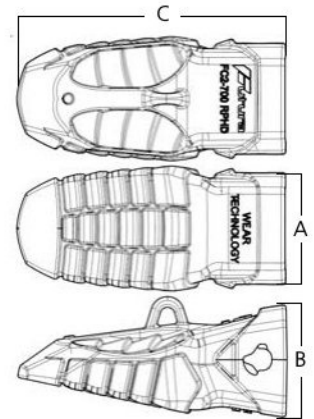

A	in	B	mm	in	C	in		Lb	Part#	OEM		SIZE
210	8,27"	212	8,35"	504	19,84"	74,5	164	<b>FC2-700 RPHD</b>	135-9700	FC700HL2		<b>70</b>

**Teeth ROCK PENETRATION LIGHT Diente PENETRACIÓN LIGERO**

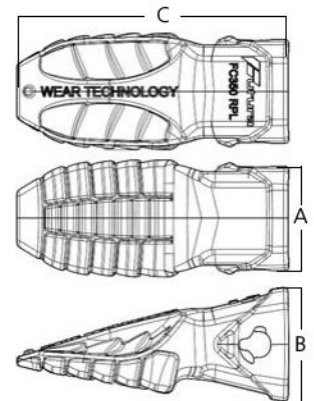

A	in	B	mm	in	C	in		Lb	Part#	OEM		SIZE
81	3,19"	89	3,50"	211	8,31"	3,9	9	<b>FC2-250 RPL</b>	9N-4252	FC250HL2		<b>25</b>
93	3,66"	105	4,13"	241	9,49"	6,3	14	<b>FC2-300 RPL</b>	9N-4302	FC300HL2		<b>30</b>
106	4,17"	116	4,57"	275	10,83"	8,6	19	<b>FC2-350 RPL</b>	9N-4352	FC350HL2		<b>35</b>
125	4,92"	132	5,20"	291	11,46"	12,1	27	<b>FC2-400 RPL</b>	8E-4402	FC400HL2		<b>40</b>
134	5,28"	140	5,51"	335	13,19"	17,5	39	<b>FC2-450 RPL</b>	9N-4452	FC450HL2		<b>45</b>
162	6,38"	163	6,42"	362	14,25"	23,0	51	<b>FC2-550 RPL</b>	9N-4552	FC550HL2		<b>55</b>
192	7,56"	190	7,48"	439	17,28"	40,1	88	<b>FC2-600 RPL</b>	7Y-0602	FC600HL2		<b>60</b>

## Teeth LONG Diente LARGO

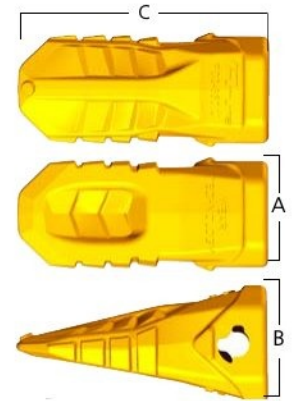
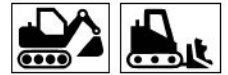

A	in	B	mm	in	C	in	kg	Lb	Part#	OEM	Image	SIZE
62	2,44"	66	2,60"	159	6,26"	1,6	4	FC2-200 L	1U-3202	FC200HL2		20
75	2,95"	81	3,19"	172	6,77"	2,1	5	FC2-220 L	6Y-3222	FC220HL2		22
81	3,19"	89	3,50"	210	8,27"	3,4	7	FC2-250 L	1U-3252	FC250HL2		25
93	3,66"	104	4,09"	220	8,66"	4,7	10	FC2-300 L	1U-3302	FC300HL2		30
106	4,17"	116	4,57"	256	10,08"	6,9	15	FC2-350 L	1U-3352	FC350HL2		35
119	4,69"	128	5,04"	274	10,79"	8,4	18	FC2-400 L	7T-3402	FC400HL2		40
134	5,28"	140	5,51"	312	12,28"	13,1	29	FC2-450 L	9W-8452	FC450HL2		45
162	6,38"	164	6,46"	361	14,21"	20,1	44	FC2-550 L	9W-8552	FC550HL2		55
187	7,36"	190	7,48"	422	16,61"	29,9	66	FC2-600 L	6I-6602	FC600HL2		60

## Teeth ROCK CHISEL Diente CINCEL ROCA

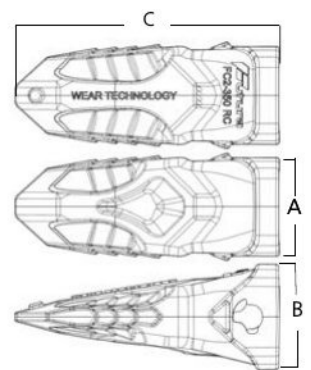

A	in	B	mm	in	C	in	kg	Lb	Part#	OEM	Image	SIZE
62	2,44"	66	2,60"	159	6,26"	1,4	3	FC2-200 RC	1U-3202 RC	FC200HL2		20
81	3,19"	94	3,70"	220	8,66"	4,0	9	FC2-250 RC	1U-3252 RC	FC250HL2		25
93	3,66"	100	3,94"	247	9,72"	5,8	13	FC2-300 RC	1U-3302 RC	FC300HL2		30
106	4,17"	114	4,49"	285	11,22"	8,6	19	FC2-350 RC	1U-3352 RC	FC350HL2		35
125	4,92"	130	5,12"	295	11,61"	11,2	25	FC2-400 RC	7T-3402 RC	FC400HL2		40
134	5,28"	132	5,20"	338	13,31"	15,6	34	FC2-450 RC	9W-8452 RC	FC450HL2		45
162	6,38"	161	6,34"	381	15,00"	25,4	56	FC2-550 RC	9W-8552 RC	FC550HL2		55
193	7,60"	188	7,40"	440	17,32"	41,9	92	FC2-600 RC	6I-6602 RC	FC600HL2		60
210	8,27"	207	8,15"	483	19,02"	52,6	116	FC2-700 RC	4T-4702 RC	FC700HL2		70
244	9,61"	244	9,61"	523	20,59"	81,0	178	FC2-800 RC		FC800HL2		80

**Teeth SYMMETRIC Diente SIMÉTRICO**

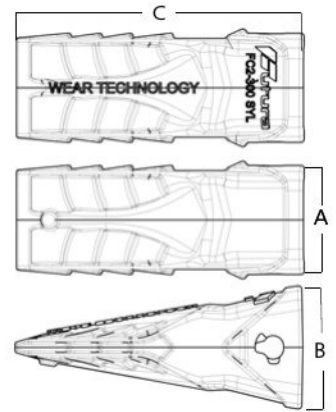
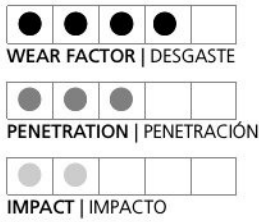

A	in	B	mm	in	C	in		Lb	Part#	OEM		SIZE
62	2,44"	66	2,60"	155	6,10"	1,3	3	<b>FC2-200 SYL</b>	1U-3202 SYL	FC200HL2		<b>20</b>
93	3,66"	105	4,13"	244	9,61"	5,5	12	<b>FC2-300 SYL</b>	1U-3302 SYL	FC300HL2		<b>30</b>
107	4,21"	118	4,65"	268	10,55"	7,0	15	<b>FC2-350 SYL</b>	1U-3352 SYL	FC350HL2		<b>35</b>
134	5,28"	140	5,51"	324	12,76"	13,7	30	<b>FC2-450 SYL</b>	9W-8452 SYL	FC450HL2		<b>45</b>

**Teeth UNIVERSAL Diente UNIVERSAL**

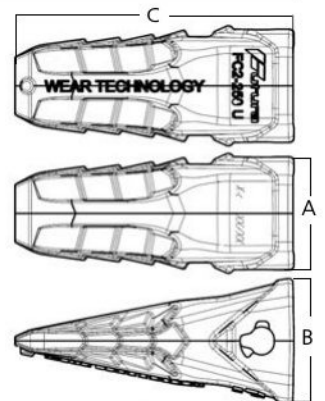
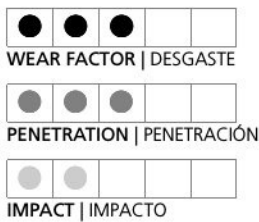

A	in	B	mm	in	C	in		Lb	Part#	OEM		SIZE
81	3,19"	89	3,50"	198	7,80"	3,1	7	<b>FC2-250 U</b>	1U-3252	FC250HL2		<b>25</b>
94	3,70"	105	4,13"	213	8,39"	4,2	9	<b>FC2-300 U</b>	1U-3302	FC300HL2		<b>30</b>
106	4,17"	117	4,61"	242	9,53"	6,0	13	<b>FC2-350 U</b>	1U-3352	FC350HL2		<b>35</b>
134	5,28"	140	5,51"	293	11,54"	10,9	24	<b>FC2-450 U</b>	9W-8452	FC450HL2		<b>45</b>
162	6,38"	161	6,34"	351	13,82"	21,6	48	<b>FC2-550 U</b>	9W-8552	FC550HL2		<b>55</b>
192	7,56"	188	7,40"	411	16,18"	35,6	78	<b>FC2-600U</b>	6I-6602	FC600HL2		<b>60</b>

# Teeth TWIN TIGER SHARP Diente DOBLE PUNTA AFILADO

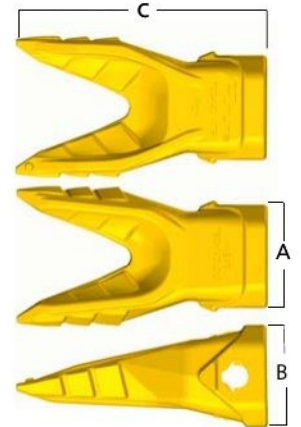

A	in	B	mm in	C	in		Lb	Part#	OEM		SIZE
62	2,44"	66	2,60"	170	6,69"	1,4	3	<b>FC2-200 WTS</b>	135-8208	FC200HL2	<b>20</b>
93	3,66"	100	3,94"	248	9,76"	5,3	12	<b>FC2-300 WTS</b>	135-9308	FC300HL2	<b>30</b>
106	4,17"	114	4,49"	262	10,31"	6,8	15	<b>FC2-350 WTS</b>	135-9337	FC350HL2	<b>35</b>
134	5,28"	132	5,20"	324	12,76"	12,4	27	<b>FC2-450 WTS</b>	135-9408	FC450HL2	<b>45</b>

**Teeth VECTOR TIGER LONG Diente LARGO VECTOR**



● ● ● | WEAR FACTOR | DESGASTE

● ● ● ● ● | PENETRATION | PENETRACIÓN

● ● | IMPACT | IMPACTO

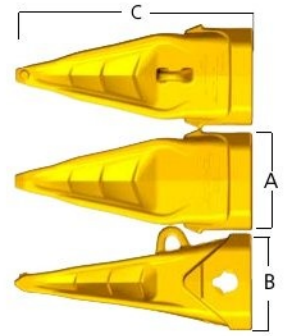

A	in	B	mm	in	C	in	kg	Lb	Part#	OEM		SIZE
98	3,86"	103	4,06"	362	14,25"	13,0	29	29	<b>FC2-450 VTL</b>	7T-8459	FC450HL2	<b>45</b>
162	6,38"	161	6,34"	395	15,55"	19,2	42	42	<b>FC2-550 VTL</b>	9W-6559	FC550HL2	<b>55</b>
192	7,56"	188	7,40"	463	18,23"	33,0	73	73	<b>FC2-600 VTL</b>	107-8609	FC600HL2	<b>60</b>
210	8,27"	209	8,23"	507	19,96"	44,6	98	98	<b>FC2-700 VTL</b>	4T-4702	FC700HL2	<b>70</b>
246	9,69"	232	9,13"	609	23,98"	68,0	150	150	<b>FC2-800 VTL</b>		FC800HL2	<b>80</b>



**Teeth VECTOR TIGER LONG Diente LARGO VECTOR**

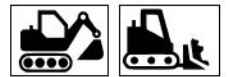

● ● ● | WEAR FACTOR | DESGASTE

● ● ● ● ● | PENETRATION | PENETRACIÓN

● ● | IMPACT | IMPACTO

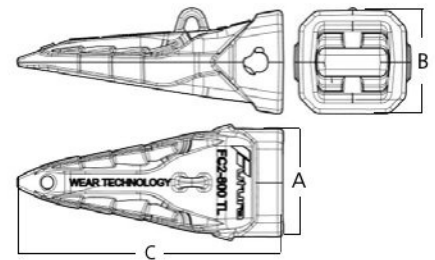

A	in	B	mm	in	C	in	kg	Lb	Part#	OEM		SIZE
250	9,84"	235	9,25"	602	23,70"	67,0	147	147	<b>FC2-800 TL</b>	-	FC800HL2	<b>80</b>





# **FC2**

## **PROPRIETARY SYSTEM**



# **ADAPTERS**

# **PORTADIENTES**

**Limited sale to authorized Futura dealers**  
Venta limitada a distribuidores autorizados FUTURA

### Guide to part sizes by Maximum Machine Weight (tons)

Guía para la elección de tallas según peso máximo de la máquina (en toneladas)

	SIZE	200	225	250	300	350	400	460	550	600	700	800
	Standard	8,7	11,5	16,7	25,0	33,8	46,9	63,6	81,2	103,7	144,1	248,4
	HD	6,8	8,9	12,9	19,5	25,0	33,4	46,9	63,6	81,2	103,7	136,4
	ST/HD	7,1	10,0	15,7	21,7	29,4	39,9	53,3	67,4	88,8	119,9	188,0
	Extra HD	5,4	7,6	12,0	16,3	22,1	30,2	39,9	53,3	67,4	88,8	129,9
	ST/HD							62,2	82,9	110,0	161,1	
	Extra HD							48,6	62,2	82,9	120,4	

Light Construction Construcción Ligera	Construction Construcción	Heavy Construction Construcción Pesada	Mining Mining
---	------------------------------	---	------------------

# FC2

## PROPRIETARY SYSTEM

# ADAPTERS

## PORTADIENTES

### BOTTOM LEG Adapter Portadiente UNIVERSAL

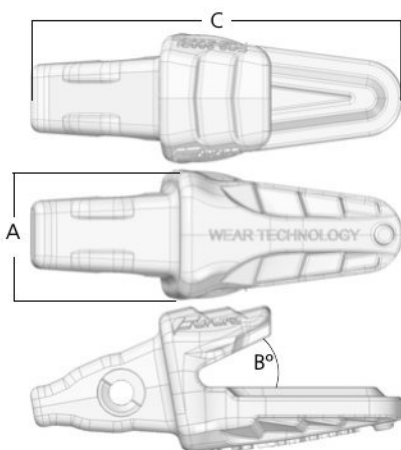

mm		in		B°	in	Lb	Part#	OEM	SIZE					
A	61	2,40"	C	175	6,89"	25	13-25	0,51"-0,98"	1,7	4	<b>FC2-200 BL</b>	8J-7525	FC200HL2	<b>20</b>



**EXCAVATOR Adapter** Portadientes EXCAVADORA

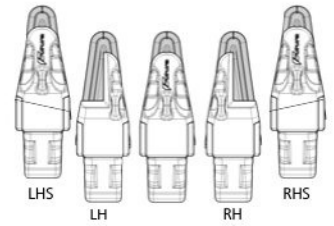
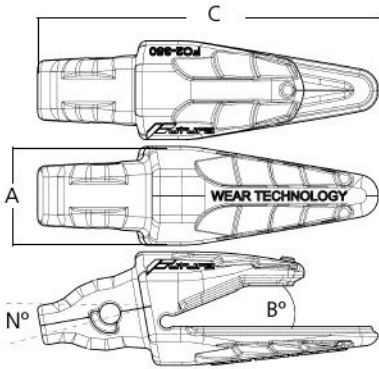

mm																
A	in	C	in	N°	B°		in		Lb	Part#	OEM			SIZE		
75	2,95"	225	8,86"	10	22	25	0,98"	3,1	7	<b>FC2-220</b>	6Y-3224	●		FC220HL2 <b>22</b>		
79	3,11"	253	9,96"	10	22	25	0,98"	4,6	10	<b>FC2-250-25</b>	6Y-3254	●		FC250HL2 <b>25</b>		
75	2,95"	258	10,16"	10	22	30	1,18"	4,5	10	<b>FC2-250</b>	119-3253	●		FC250HL2 <b>25</b>		
96	3,78"	328	12,91"	10	22	30 32	1,2" 1,3"	8,0	18	<b>FC2-300</b>	3G-6304	●		FC300HL2 <b>30</b>		
90	3,54"	330	12,99"	10	22	35	1,38"	7,9	17	<b>FC2-300-35</b>	8E-9490	●		FC300HL2 <b>30</b>		
104	4,09"	358	14,09"	10	22	40	1,57"	10,1	22	<b>FC2-350</b>	6I-6354	●		FC350HL2 <b>35</b>		
104	4,09"	359	14,13"	10	35	40	1,57"	10,5	23	<b>FC2-350-B35</b>	3G-8354	●		FC350HL2 <b>35</b>		
125	4,92"	402	15,83"	10	22	45	1,77"	15,3	34	<b>FC2-400</b>	6I-6404	●		FC400HL2 <b>40</b>		
										<b>FC2-450</b>	6I-6464	●		FC450HL2 <b>40</b>		
135	5,31"	438	17,24"	10	22	50	1,97"	20,6	45	<b>FC2-450 LHS</b>		● 15°		FC450HL2 <b>45</b>		
										<b>FC2-450 RHS</b>		15° ●				

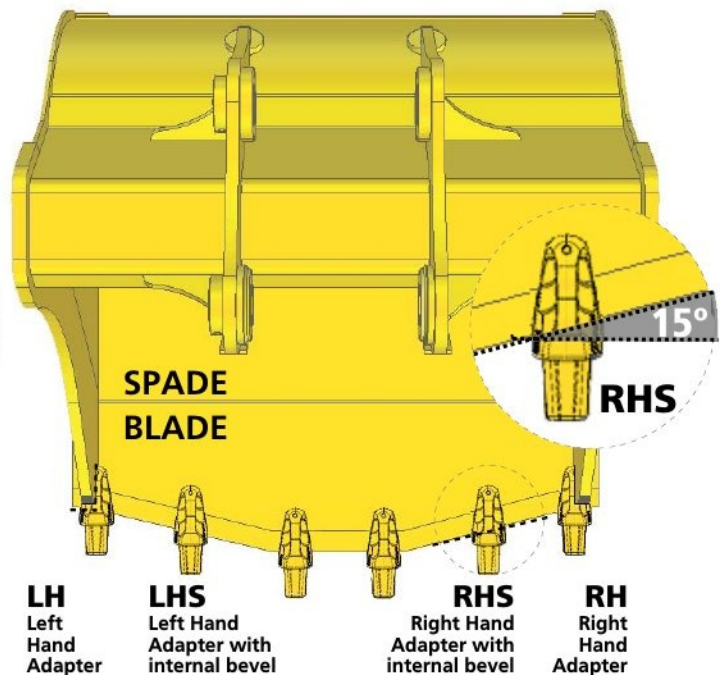
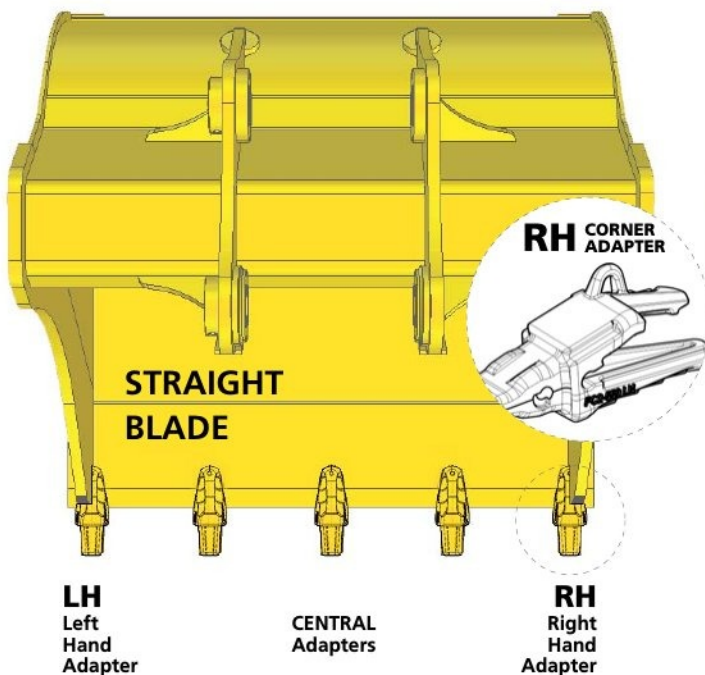

# EXCAVATOR Adapter Portadientes EXCAVADORA

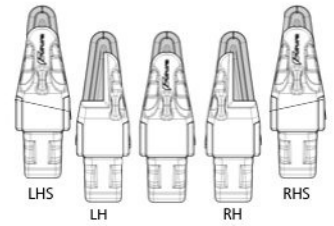

mm																					
A	in	C	in	N°	B°		in		Lb	Part#	OEM				SIZE						
								35,3	78	<b>FC2-550</b>	6I-6554	●									
								33,2	73	<b>FC2-550 LH</b>	6I-6556	●									
160	6,30"	514	20,24"	10	22	60	2,36"	33,2	73	<b>FC2-550 RH</b>	6I-6555	●	15°		F5559 WC	FC550HL2	<b>55</b>				
								35,4	78	<b>FC2-550 LHS</b>	105-6270	●	15°								
								35,4	78	<b>FC2-550 RHS</b>	105-6269	●	15°								
								62,1	137	<b>FC2-600</b>	6I-6604	●									
								56,8	125	<b>FC2-600 LH</b>	6I-6606	●									
190	7,48"	569	22,40"	10	22	70 75	2,80" 3"	56,8	125	<b>FC2-600 RH</b>	6I-6605	●			F6061 WC	FC600HL2	<b>60</b>				
								62,4	137	<b>FC2-600 LHS</b>		●	15°								
								62,4	137	<b>FC2-600 RHS</b>		●	15°								
190	7,48"	569	22,40"	10	22	80	3,15"	61,5	135	<b>FC2-600-80</b>	119-8604	●									
								83,1	183	<b>FC2-700</b>	222-7700	●									
								81,8	180	<b>FC2-700 LH</b>		●									
375	14,76"	628	24,72"	10	35	90	3,50"	81,8	180	<b>FC2-700 RH</b>		●									
								89,5	197	<b>FC2-700 LHS</b>		●	15°		F7069 WC	FC700HL2	<b>70</b>				
								89,5	197	<b>FC2-700 RHS</b>		●	15°								
								87,1	192	<b>FC2-700-95</b>		●									
375	14,76"	628	24,72"	10	35	95	3,74"	82,4	181	<b>FC2-700-95 LH</b>		●									
								82,4	181	<b>FC2-700-95 RH</b>		●									
								122,0	268	<b>FC2-800</b>	6I-8804	●									
462	18,19"	720	28,35"	10	30	100	3,94"	117,9	259	<b>FC2-800 LH</b>		●		F8071 WC	FC800HL2	<b>80</b>					
								117,9	259	<b>FC2-800 RH</b>		●									

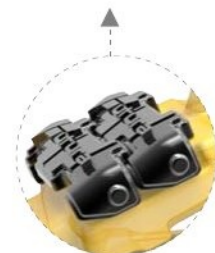

Optional Wear Cap

Protector de Portadientes opcional



**LOADER Adapter** Portadientes CARGADORA

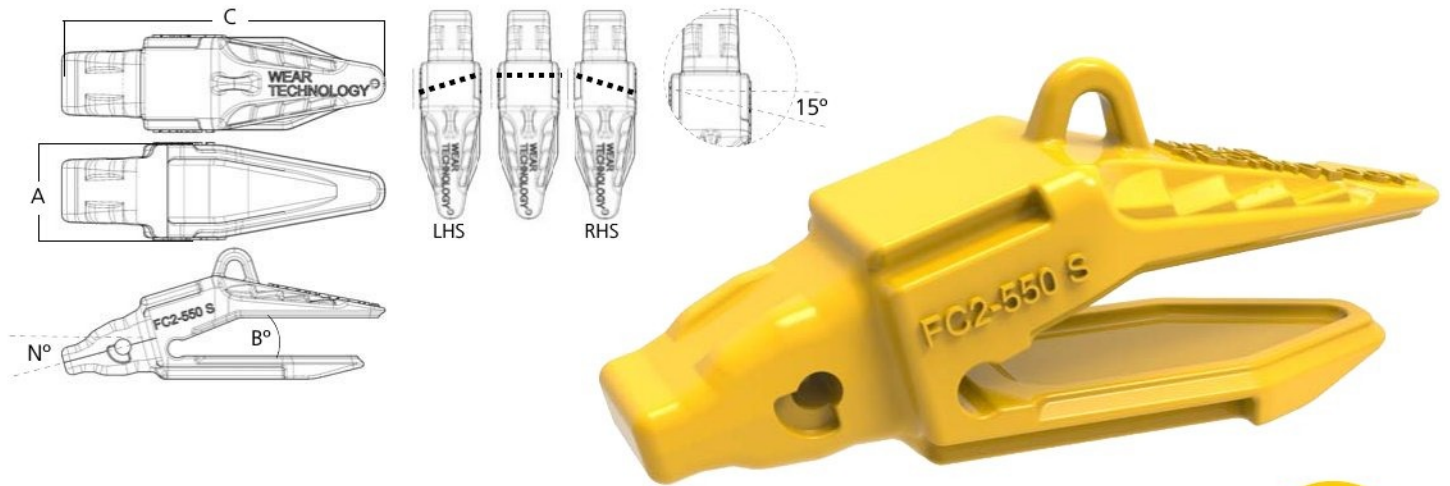

mm		in		N° B°		in		Lb		Part#	OEM	SIZE	
A		C											
60	2,36"	554	21,81"	15	22	41	90	<b>FC2-550 S</b>	107-3554				
63	2,48"					42	92	<b>FC2-550 S LHS</b>	107-3556		F5559 WC	FC550HL2	<b>55</b>
						42	92	<b>FC2-550 S RHS</b>	107-3555				
						66	145	<b>FC2-600 S</b>	119-8604				
75	2,95"	586	23,07"	15	22	68	149	<b>FC2-600 S LHS</b>	119-8606		F6061 WC	FC600HL2	<b>60</b>
						68	149	<b>FC2-600 S RHS</b>	119-8605				
						76	167	<b>FC2-700 S</b>	133-0704				
70	2,76"	572	22,52"	17	22	78	171	<b>FC2-700 S LHS</b>	133-0706		F7069 WC	FC700HL2	<b>70</b>
						78	171	<b>FC2-700 S RHS</b>	133-0705				
100	3,94"	701	27,60"	15	22	121	266	<b>FC2-800 S</b>	61-8804		F8071 WC	FC800HL2	<b>80</b>

**LOADER BUCKET**  
CAZO / CUCHARÓN CARGADORA

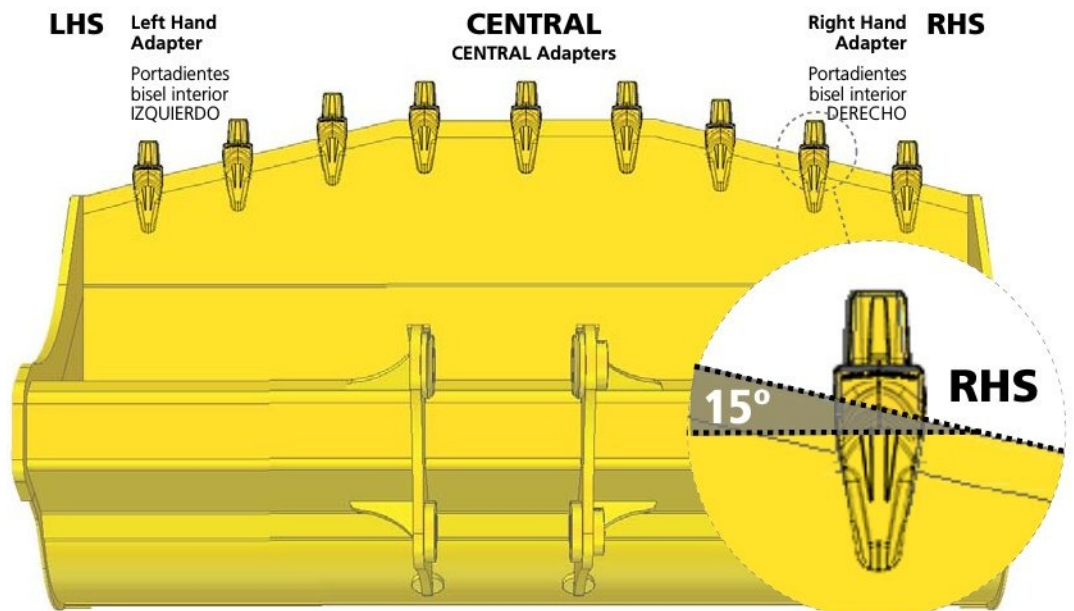

# OPTIONAL Wear Caps Protectores Portadiente OPCIONALES

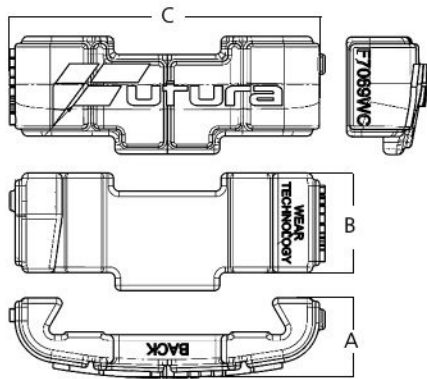

mm.						SIZE
A	B	C				
42,7 1,68"	50,5 1,99"	178 7,01"	1,70 3,75			55
45,2 1,78"	62,5 2,46"	207 8,15"	2,42 5,34			60
51,9 2,04"	71,5 2,81"	219 8,62"	3,23 7,12			70
53,1 2,09"	93,5 3,68"	251 9,88"	4,50 9,92			80

### QUICK, EASY INSTALLATION

Just slide the wear caps throught the adapter guides.

### STOCK SAVING

Each wear cap could be mounted on various FUTURA adapters. Wear caps help prolong the wear life of each adapter.



### MONTAJE RÁPIDO Y FÁCIL

Es suficiente con deslizar los protectores a lo largo de las guías del portadientes

### AHORRO EN STOCK

Estos protectores universales pueden utilizarse en varios adaptadores de la marca FUTURA. Los protectores FUTURA alargan la vida útil de los portadientes.



**ASSEMBLY INSTRUCTIONS**

ENGLISH

⦿ The FUTURA hammerless system HL2 works **only with FUTURA teeth** ⦿ For **Adapters FC2** omit step 1

1 Insert the washer into the adapter washer hole as shown in the picture 2 Mount the tooth on the adapter 3 Insert the pin into the hole 4 Use a SOCKET HEX or a HEX KEY (check the HEX TABLE below for recommended keys for each pin) to rotate the pin from any of its ends. A rubber insert under locking tab allows the locking tab (fig 5) to compress, rotate and lock. 6 Each pin comes with a heavy duty dirt plug to keep fines out of the pin's socket. Choose the right plug according to the tooth recess and place. Discard the other plug.

**Disassembly** Repeat steps in reverse order.

**INSTRUCCIONES DE MONTAJE**

ESPAÑOL

⦿ El sistema FUTURA Hammerless HL2 FUNCIONA SOLO CON DIENTES MARCA FUTURA ⦿ Para el montaje con portadientes FC2 omite el paso 1

1 Inserte la arandela en el hueco del portadientes en la posición que se indica 2 Encaje el diente en el portadientes 3 Coloque el pasador en el orificio del diente como se indica 4 Utilice una llave ALLEN o un VASO HEXAGONAL para girar el pasador (compruebe el tamaño de la llave en la tabla más abajo) 5 El mecanismo de fijación del pasador permite que la pestaña de cierre se comprima, rote y bloquee el diente 6 Los pasadores HL2 van acompañados de un tapón de goma anti-suciedad para sus extremos. Elija el que mejor se ajuste y colóquelo en posición. Los tapones de goma ayudan a prevenir la entrada de suciedad. Deseche el tapón sobrante.

**Desmontaje** Repetir los pasos en orden inverso.

**INSTRUCTIONS DE MONTAGE**

FRANÇAIS

⦿ Le système de montage sans marteau FUTURA HL2 fonctionne **uniquement avec FUTURA dents** ⦿ Pour **Adaptateurs FC2** passer l'étape 1

1 Insérer la rondelle dans le trou de l'adaptateur comme montré dans l'image 2 Montez la dent sur l'adaptateur 3 Insérez la goupille dans le trou 4 Aussi facile à installer qu'à retirer avec une clé Allen standard ou une socket HEX (vérifier la taille de la clé dans le tableau). Les goupilles sont retenues en place en toute sécurité par le mécanisme de loquet muni de l'insertion de caoutchouc sous la barrure qui permet de compresser, tourner et barrer en place (fig 5) 6 Chaque goupille vient avec un bouchon pour empêcher la saleté de pénétrer dans les extrémités.

**Démontage** Répétez les étapes dans l'ordre inverse.

**INSTRUÇÕES DE MONTAGEM**

PORTUGUÊS

⦿ El sistema HL2 funciona **exclusivamente com pontas FUTURA** ⦿ Para **Adaptadores FC2** omitir o passo 1

1 Inserir na anilha no orifício na posição indicada 2 Montar a ponta no adaptador 3 Colocar a cavilha no orifício da ponta 4 Use uma chave Allen (hex) ou um soquete HEX para ligar a cavilha (verificar o tamanho da chave no quadro) 5 O mecanismo de fixação permite que o encaixe da borracha se comprima, rode e bloqueie a peça com uma simples rotação de 90° 6 Cada trava vêm acompanhado de um tampão para evitar a entrada de sujidade nas extremidades

**Desmontagem** repita os passos na ordem inversa.

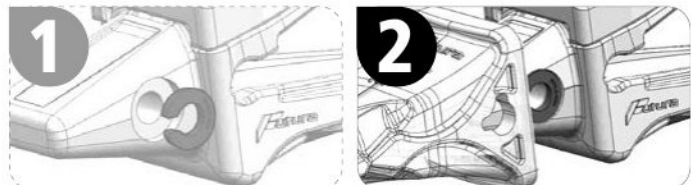

DRP FC2		PHL	
SOCKET HEX	HEX KEY	SOCKET HEX	HEX KEY
M7 9/32"	HL2-200	M8 5/16"	
M10 3/8"	HL2-220	M8 5/16"	
M10 3/8"	HL2-250	M8 5/16"	
M10 3/8"	HL2-300	M8 5/16"	
M13 1/2"	HL2-350	M10 3/8"	
M14 9/16"	HL2-400	M12 1/2"	
M15 5/8"	HL2-450	M12 1/2"	
M15 5/8"	HL2-550	M12 1/2"	
M20 13/16"	HL2-600	M17 11/16"	
M22 7/8"	HL2-700	M17 11/16"	
M24 15/16"	HL2-800	M19 3/4"	

OEM Cross Refs (WHEN USING FUTURA TOOTH)				SIZE
L mm	L in	Ø mm	Ø in	
61	2,40"	11	0,43"	FC200HL2 8E-6208, 1U-4208 8E-6209, 4T-0001 <b>20</b>
69	2,72"	14	0,55"	FC220HL2 132-4762, 6Y-3228 8E-6259, 3G-9609, 149-5733 <b>22</b>
79	3,11"	14	0,55"	FC250HL2 8E-6258, 132-4763, 9J-2258 8E-6259, 3G-9609, 149-5733 <b>25</b>
94	3,70"	15	0,59"	FC300HL2 107-3308, 132-4766, 9J-2308 8E-6259, 3G-9609, 149-5733 <b>30</b>
104	4,09"	20	0,79"	FC350HL2 8E-6358, 114-0358, 9J-2358 8E-6359, 3G-9548, 114-0359 <b>35</b>
118	4,65"	22	0,87"	FC400HL2 7T-3408, 116-7408 8E-8409, 116-7409 <b>40</b>
136	5,35"	24	0,94"	FC450HL2 8E-0468, 114-0468 8E-8469, 107-3469 <b>45</b>
159	6,26"	25	0,98"	FC550HL2 6Y-8558, 107-3378, 1U-1558 8E-5559, 3G-9559, 107-8559 <b>55</b>
195	7,68"	30	1,18"	FC600HL2 6I-6608, 113-9608 6I-6609, 113-9609 <b>60</b>
204	8,03"	32	1,26"	FC700HL2 4T-4708, 113-4708 4T-4707, 113-4709 <b>70</b>
238	9,37"	35	1,38"	FC800HL2 134-1808, 102-0101 101-2874, 134-1809 <b>80</b>
105	4,13"	15	0,59"	FD33 PHL 132-4766 8E-6259, 149-5733 <b>33</b>



# HAMMERLESS PIN Pasador HL2



FAST THE HAMMERLESS PIN FROM ANY OF ITS HEXAGONAL ENDS

EL PASADOR SE PUEDE MONTAR POR CUALQUIERA DE SUS DOS EXTREMOS CON HERRAMIENTAS ESTÁNDAR



L	mm		in	Ø	in	Lb	FC	OEM PIN	OEM WASHER	SIZE	Washer Size	
	in	Ø									M	M
61	2,40"	11	0,43"	0,04	0,1	<b>FC200HL2</b>	8E-6208, 1U-4208	8E-6209, 4T-0001	<b>20</b>	M7 9/32"	M8 5/16"	
69	2,72"	14	0,55"	0,10	0,2	<b>FC220HL2</b>	132-4762, 6Y-3228	8E-6259, 3G-9609	<b>22</b>	M10 3/8"	M8 5/16"	
79	3,11"	14	0,55"	0,12	0,3	<b>FC250HL2</b>	8E-6258, 132-4763	8E-6259, 3G-9609	<b>25</b>	M10 3/8"	M8 5/16"	
94	3,70"	15	0,59"	0,15	0,3	<b>FC300HL2</b>	107-3308, 132-4766	8E-6259, 3G-9609	<b>30</b>	M10 3/8"	M8 5/16"	
104	4,09"	20	0,79"	0,29	0,6	<b>FC350HL2</b>	8E-6358, 114-0358	8E-6359, 3G-9548	<b>35</b>	M13 1/2"	M10 3/8"	
118	4,65"	22	0,87"	0,38	0,8	<b>FC400HL2</b>	7T-3408, 116-7408	8E-8409, 116-7409	<b>40</b>	M14 9/16"	M12 1/2"	
136	5,35"	24	0,94"	0,48	1,1	<b>FC450HL2</b>	8E-0468, 114-0468	8E-8469, 107-3469	<b>45</b>	M15 5/8"	M12 1/2"	
159	6,26"	25	0,98"	0,65	1,4	<b>FC550HL2</b>	6Y-8558, 107-3378	8E-5559, 3G-9559	<b>55</b>	M15 5/8"	M12 1/2"	
195	7,68"	30	1,18"	1,14	2,5	<b>FC600HL2</b>	6I-6608, 113-9608	6I-6609, 113-9609	<b>60</b>	M20 13/16"	M17 11/16"	
204	8,03"	32	1,26"	1,47	3,2	<b>FC700HL2</b>	4T-4708, 113-4708	4T-4707, 113-4709	<b>70</b>	M22 7/8"	M17 11/16"	
238	9,37"	35	1,38"	2,00	4,4	<b>FC800HL2</b>	134-1808, 102-0101	101-2874, 134-1809	<b>80</b>	M24 15/16"	M19 3/4"	

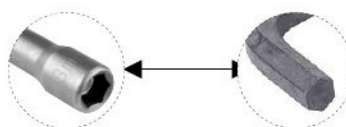

SOCKET HEX OR HEX KEY

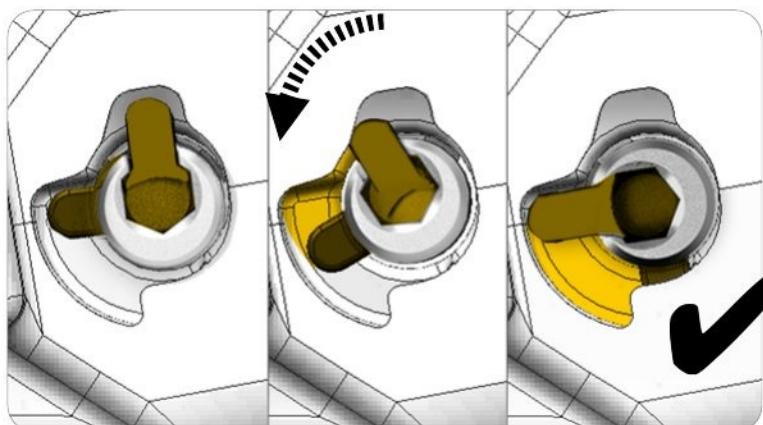

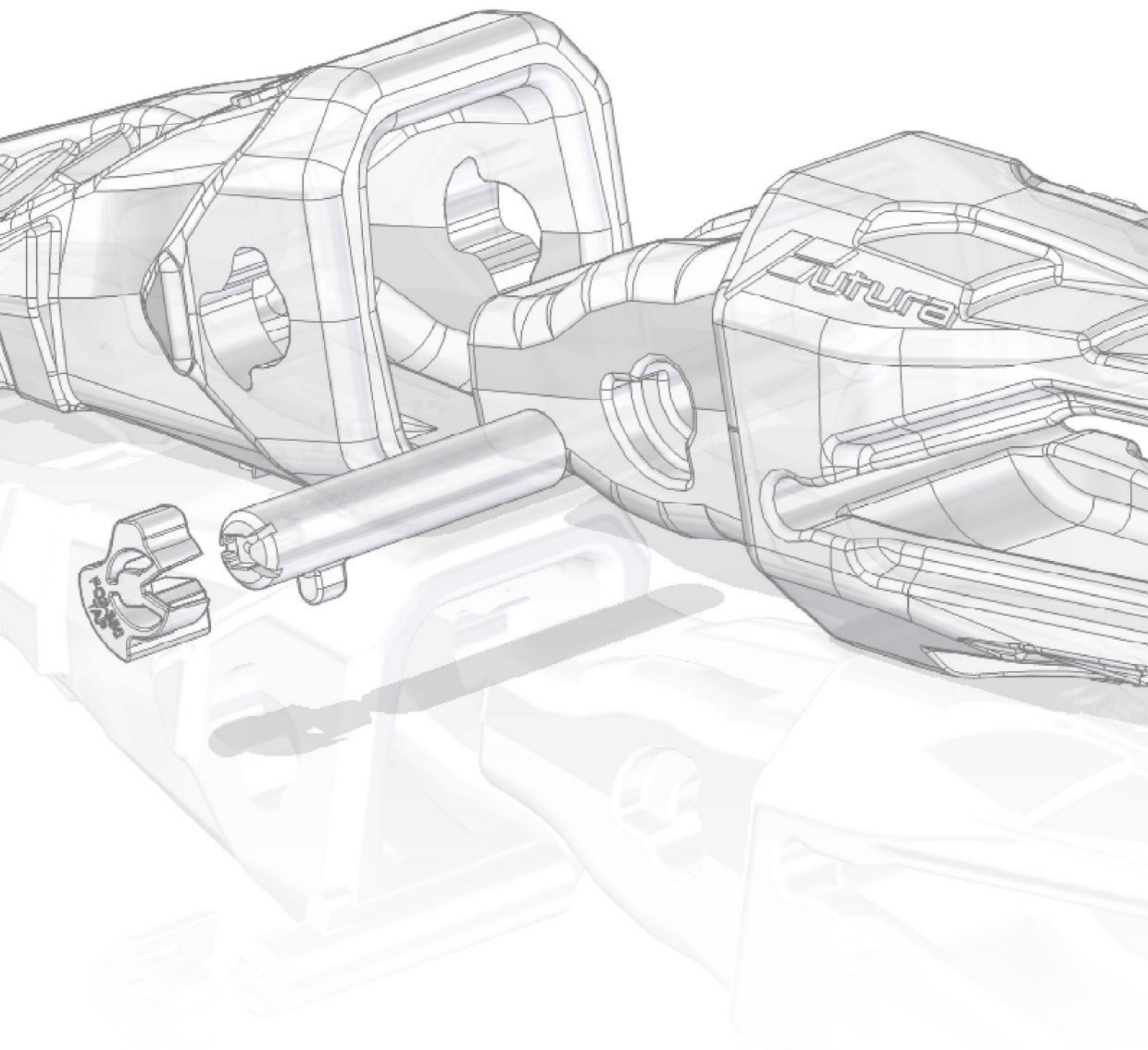

**Caterpillar**

DIRECT  
REPLACEMENT  
PARTS FOR

PIEZAS DE  
REEMPLAZO  
DIRECTO PARA

# Caterpillar

## Ripper Components Componentes Ripper

**Bold part number,  
available product**  
*Other part numbers  
please consult*

**Referencia en negrita  
producto disponible**  
*Otras referencias  
consúltenos*

**Key to part numbers**

**Codificación Referencias**

**F C 4 5 0 R 1**

Brand / Marca

Type / Tipo

Size / Tamaño

Version / Versión

Ripper / Ripper

Short / Corto



**BULLDOZER BULLDOZER**



R1	R2	R2S	R2ST	R3	R3ST	R2P		
-	FC300 R2	-	-	-	-	-	D4 963, 14, 12	<b>R300</b>
-	FC350 R2	-	FC350 R2ST	-	-	-	D5, D6, 973, 16, 977, D7	<b>R350</b>
FC450 R1	FC450 R2	-	FC450 R2ST	FC450 R3	-	-	D8, D8 L, D9, D8 K, D8C, D8 N, D9 H, D9 N	<b>R450</b>
FC500 R1	FC500 R2	FC500 R2S	FC500 R2ST	FC500 R3	FC500 R3ST	FC500 R2P	D10 N	<b>R500</b>
FC550 R1	FC550 R2	FC550 R2S	-	-	-	-	D10 N, D11SS	<b>R550</b>



Theoretical weights, subject to variations Pesos teóricos, sujetos a variaciones | Manufacturer's names, descriptions, pictures and part numbers are used for reference purposes only. Los nombres, descripciones, ilustraciones y referencias de otras marcas se utilizan a modo de referencia.

**Caterpillar**

**R1 Short Ripper Teeth** Diente Ripper Corto

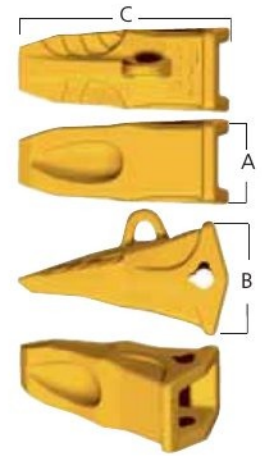

mm.				REF	OEM		REUSABLE		NO REUSABLE		STANDARD	HAMMERLESS	R
A	B	C	KG										
139 5,47"	186 7,32"	344 13,54"	19,30 330	<b>FC450 R1</b>	9W-2451	4T-5451	6Y-3394	-	-	-	8E-4743	FCR450HP	<b>R450</b>
156 6,14"	219 8,62"	414 16,30"	32,50 71,65	<b>FC500 R1</b>	4T-4501	4T-5501	6Y-3909	4T-4707	6Y-1204	6Y-1202	-	FCR500HP	<b>R500</b>
176 6,93"	254 10,00"	480 18,90"	51,90 114,42	<b>FC550 R1</b>	9W-4551	-	8E-2229	8E-2230	9N-4245	6Y-1205	-	FCR550HP	<b>R550</b>

**R2 Medium Ripper Teeth** Diente Ripper Intermedio

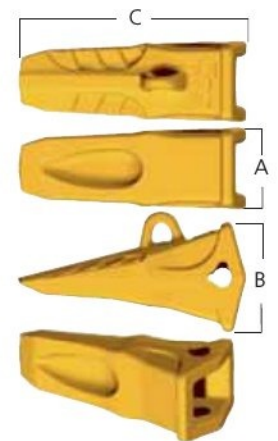

mm.				REF	OEM		REUSABLE		NO REUSABLE		STANDARD	HAMMERLESS	R
A	B	C	KG										
94 3,70"	114 4,49"	295 11,61"	6,30 330	<b>FC300 R2</b>	4T-4302	6Y-0309	9J-6583	-	-	-	1U-2405	FCR300HP	<b>R300</b>
123 4,84"	164 6,46"	342 13,46"	14,50 31,97	<b>FC350 R2</b>	6Y-0352	6Y-0359	8E-6358	-	-	-	1U-2405	FCR350HP	<b>R350</b>
139 5,47"	186 7,32"	388 15,28"	25,00 55,11	<b>FC450 R2</b>	9W-2452	4T-5452	6Y-3394	-	-	-	8E-4743	FCR450HP	<b>R450</b>
157 6,18"	219 8,62"	454 17,87"	33,50 73,85	<b>FC500 R2</b>	4T-4502	4T-5502	6Y-3909	4T-4707	6Y-1204	6Y-1202	-	FCR500HP	<b>R500</b>
182 7,17"	250 9,84"	535 21,06"	55,40 122,13	<b>FC550 R2</b>	9W-4552	6Y-3552	8E-2229	8E-2230	9N-4245	6Y-1205	-	FCR550HP	<b>R550</b>

**Caterpillar**

**R2S Medium Symmetric Ripper Teeth** Diente Intermedio Simétrico

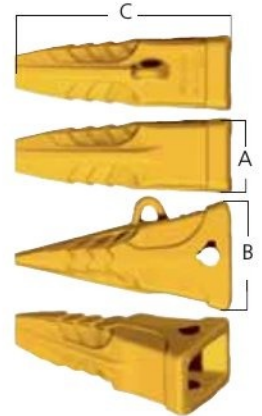

mm.			REF	OEM		REUSABLE		NO REUSABLE		HAMMERLESS	R
A	B	C									
228 8,98"	454 17,87"	36,30 80,03	<b>FC500 R2S</b>	4T-4502	-	6Y-3909	4T-4707	6Y-1204	6Y-1202	FCR500HP	<b>R500</b>
181 7,13"	277 10,91"	544 21,42"	<b>FC550 R2S</b>	9W-4552	6Y-3552	8E-2229	8E-2230	9N-4245	6Y-1205	FCR550HP	<b>R550</b>

**R2ST Medium Star Ripper Teeth** Diente Ripper Intermedio Estrella

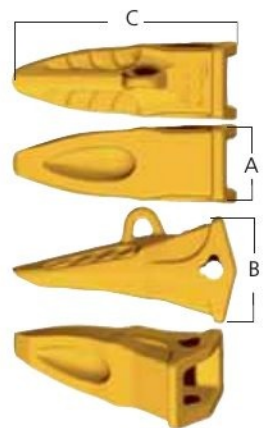

mm.				REF	OEM		REUSABLE		NO REUSABLE		STANDARD	HAMMERLESS	R
A	B	C											
122 4,80"	184 7,24"	345 13,58"	13,40 29,54	<b>FC350 R2ST</b>	6Y-0352 Star	-	8E-6358	-	-	-	1U-2405	FCR350HP	<b>R350</b>
139 5,47"	186 7,32"	392 15,43"	19,80 43,65	<b>FC450 R2ST</b>	9W-2452 Star	-	6Y-3394	-	-	-	8E-4743	FCR450HP	<b>R450</b>
157 6,18"	228 8,98"	454 17,87"	32,70 72,09	<b>FC500 R2ST</b>	4T-4502 Star	-	6Y-3909	4T-4707	6Y-1204	6Y-1202	-	FCR500HP	<b>R500</b>

**Caterpillar**

**R3 Long Ripper Teeth** Diente Ripper Largo

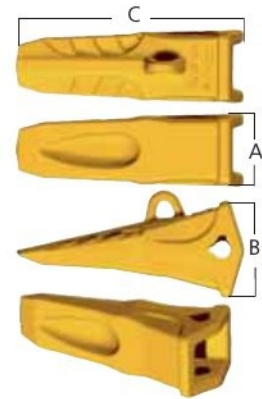

mm.				REF	OEM		REUSABLE		NO REUSABLE		STANDARD	HAMMERLESS	R
A	B	C	KG										
139 5,47"	182 7,17"	430 16,93"	22,90 330	<b>FC450 R3</b>	114-0453	-	6Y-3394	-	-	-	8E-4743	FCR450HP	<b>R450</b>
157 6,18"	219 8,62"	502 19,76"	37,40 82,45	<b>FC500 R3</b>	4T-5503 4T-4503	4T-5503	6Y-3909	4T-4707	6Y-1204	6Y-1202	-	FCR500HP	<b>R500</b>

**R3ST Long Star Ripper Tooth** Diente Ripper Largo Estrella Intermedio

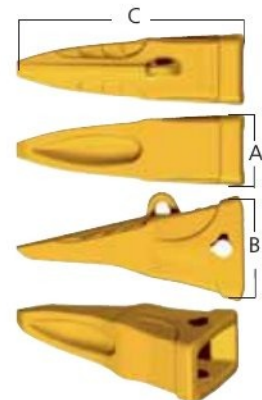

mm.				REF	OEM		REUSABLE		NO REUSABLE		HAMMERLESS	R
A	B	C	KG									
157 6,18"	228 8,98"	498 19,61"	36,60 330	<b>FC500 R3ST</b>	4T-5503 4T-4503	-	8E-2229	8E-2230	9N-4245	6Y-1205	FCR500HP	<b>R500</b>

**Caterpillar**

**R2P Replaceable Tip Tooth** Diente Punta Reemplazable



mm.					REPLACEABLE TIP PUNTA REEMPLAZABLE					mm.	
A	B	C		OEM	A	B	C				
157	228	469		4T-4501 4T-5501	132	108	240		FC500 TR2	FCR400HL2P	<b>R500</b>
6,18*	8,98*	18,46*			5,20*	4,25*	9,45*				
			<b>FC500 R2P</b>								
			*								

**\*FULL ASSEMBLY** MONTAJE COMPLETO

**Caterpillar**

**Hammerless Ripper Protector Protector Ripper Hammerless**

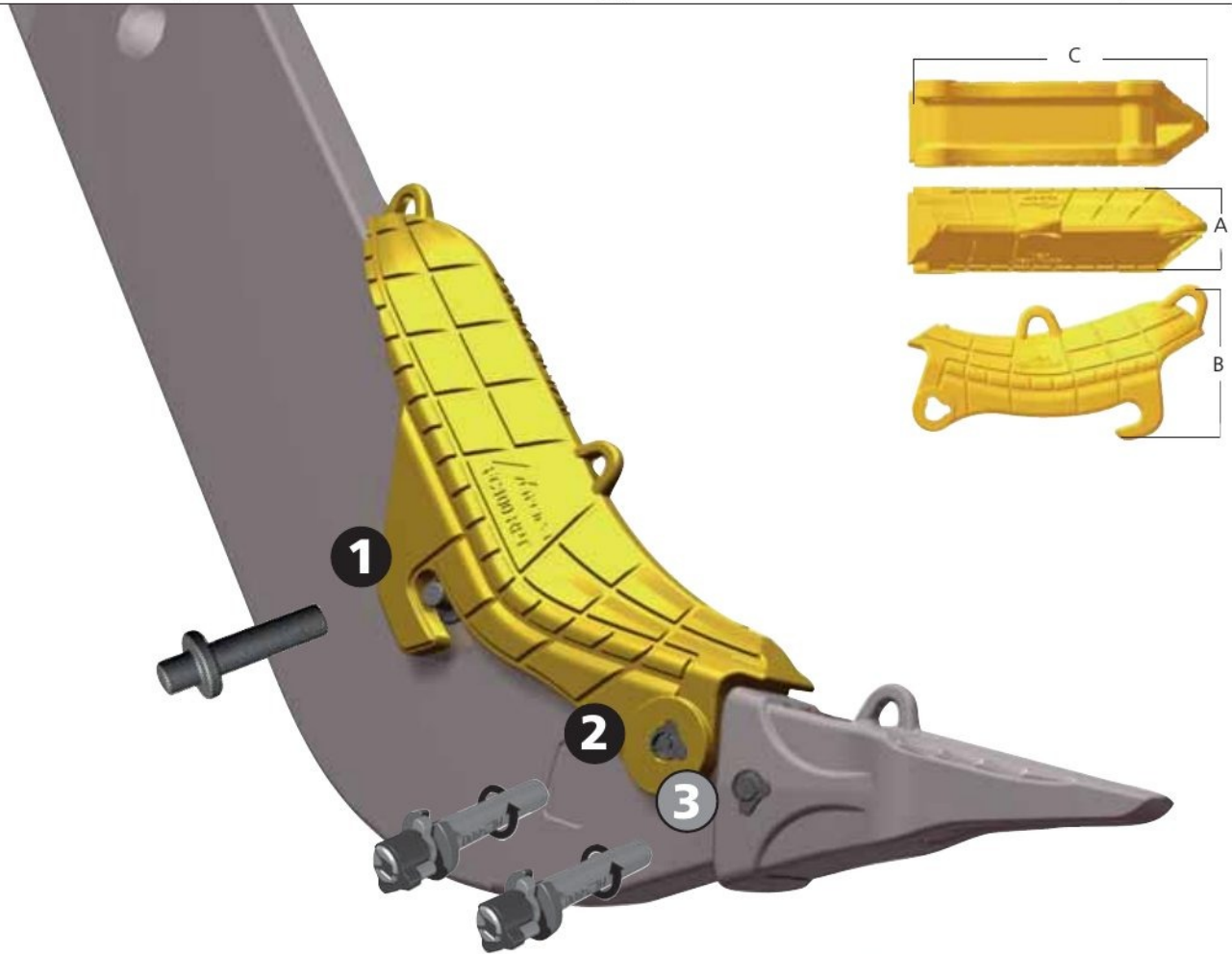

mm.					REF	OEM	<b>1</b>	<b>2</b>	<b>3</b>	
A	B	C								
141 5,55"	368 14,49"	312 12,28"	50,48 330	75 2,95"	<b>FC75 RPT</b>	STD 6J8814 EXT 132-4716	FC75 RPN	F CR450HP	F CR450HP	<b>R450</b>
182 7,17"	500 19,69"	851 33,50"	105,46 232,50	90 3,54"	<b>FC90 RPT</b>	STD 9W8365 EXT 132-1014	FC90100 RPN	F CR90100HP	F CR500HP	<b>R500</b>
182 7,17"	525 20,67"	875 34,45"	108,60 330	100 3,94"	<b>FC100 RPT</b>	STD 6Y8960 EXT 132-1015	FC90100 RPN	F CR90100HP	F CR500HP	<b>R500</b>
203 7,99"	449 17,68"	935 36,81"	146,47 322,91	110 4,33"	<b>FC110 RPT</b>	STD 9W4621 EXT 132-1016	FC110 RPN	F CR550HP	F CR550HP	<b>R550</b>







**Ripper Fasteners** Sujeción Ripper

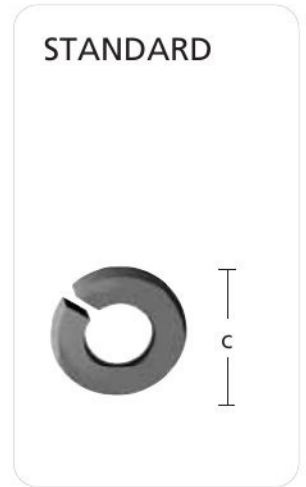

mm						REUSABLE	NO REUSABLE	STANDARD	HAMMERLESS				
A	B	C	D	E									
19 0,75"	88 3,46"	38 1,50"	20,50 0,81"	92 3,62"	0,19 0,01"	<b>9J-6583</b>	-	-	<b>1U-2405</b>	<b>FCR300HP</b>	-	<b>R300</b>	
19 0,75"	108 4,25"	38 1,50"	20,50 0,81"	120 4,72"	0,20 0,01"	<b>8E-6358</b>	-	-	<b>1U-2405</b>	<b>FCR350HP</b>	-	<b>R350</b>	
25,4 1,00"	128 5,04"	48 1,89"	26 1,02"	135 5,31"	0,47 0,02"	<b>6Y-3394</b>	-	-	<b>8E-4743</b>	<b>FCR450HP</b>	<b>FC75 RPN</b>	<b>R450</b>	
31,75 1,25"	153 6,02"	64 2,52"	33 1,30"	153 6,02"	0,93 0,04"	<b>6Y-3909</b>	<b>4T-4707</b>	<b>6Y-1204</b>	<b>6Y-1202</b>	-	<b>FCR500HP</b>	<b>R500</b>	
			33 1,30"	167 6,57"	1,10 0,04"					-	<b>FCR90100HP</b>	<b>FC90100 RPN</b>	<b>R500</b>
			37,5 1,48"	170 6,69"	1,15 0,05"	<b>8E-2229</b>	<b>8E-2230</b>	<b>9N-4245</b>	<b>6Y-1205</b>	-	<b>FCR550HP</b>	<b>FC110 RPN</b>	<b>R550</b>

# Caterpillar

## ASSEMBLY INSTRUCTIONS

ENGLISH

The FUTURA hammerless system RHP works **only with FUTURA RIPPER teeth**

1 Insert the washer into the ripper washer hole as shown in the picture 2 Mount the tooth on the ripper 3 Insert the pin into the hole. Use a SOCKET HEX or a HEX KEY (check the HEX TABLE below for recommended keys for each pin) to rotate the pin from any of its ends. A rubber insert under locking tab allows the locking tab (fig 5) to compress, rotate and lock. 6 Each pin comes with a heavy duty "dirt" plug to keep fines out of the pin's socket. Place plug.

**Disassembly** Repeat steps in reverse order.

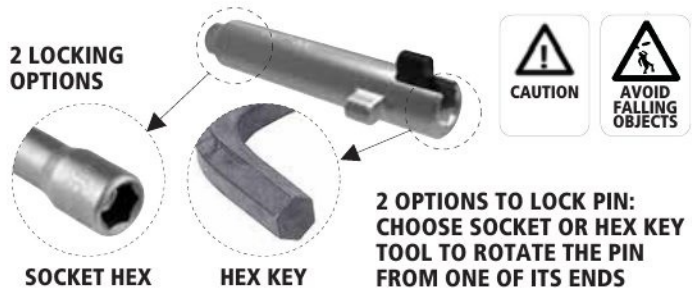

## INSTRUCCIONES DE MONTAJE

ESPAÑOL

El sistema FUTURA Hammerless RHP FUNCIONA SOLO CON DIENTES DE RIPPER MARCA FUTURA

1 Inserte la arandela en el hueco del ripper en la posición que se indica 2 Encaje el diente en el brazo de ripper 3 Coloque el pasador en el orificio del diente como se indica 4 Utilice una llave ALLEN (hexagonal) o un VASO HEXAGONAL para girar el pasador (compruebe el tamaño de la llave en la tabla de la derecha) 5 El mecanismo de fijación del pasador permite que la pestaña de cierre se comprima, rote y bloquee el diente 6 Los pasadores RHP van acompañados de un tapón de goma anti-suciedad. Coloque el tapón. El diente está listo para trabajar.

**Desmontaje** Repetir los pasos en orden inverso.

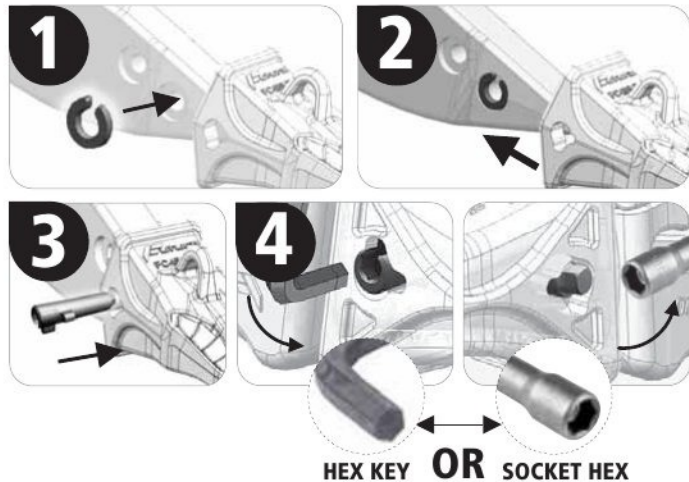

## INSTRUCTIONS DE MONTAGE

FRANÇAIS

Le système de montage sans marteau FUTURA RHP fonctionne **uniquement avec FUTURA RIPPER dents**

1 Insérer la rondelle dans le trou del ripper comme montré dans l'image 2 Montez la dent sur el ripper 3 Insérez la goupille dans le trou 4 Aussi facile à installer qu'à retirer avec une clé Allen standard ou une socket HEX (vérifier la taille de la clé dans le tableau à droite). Les goupilles sont retenues en place en toute sécurité par le mécanisme de loquet muni del'insertion de caoutchouc sous la barrure qui permet de compresser, tourner et barrer en place (fig. 5) 6 Chaque goupille vient avec un bouchon pour empêcher la saleté de pénétrer dans les extrémités. Insérer le bouchon.

**Démontage** Répétez les étapes dans l'ordre inverse.

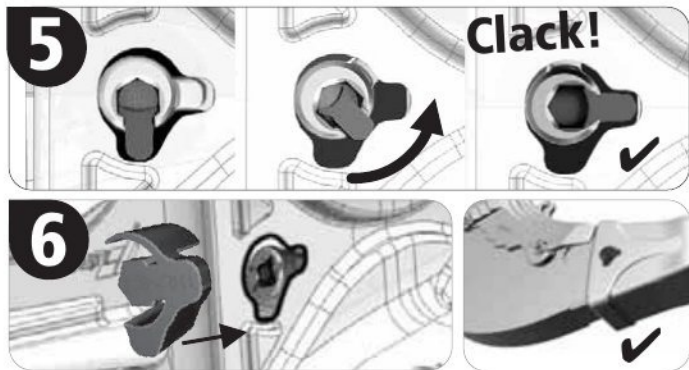

## INSTRUÇÕES DE MONTAGEM

PORTUGUÊS

The sistema RHP funciona **exclusivamente com pontas FUTURA RIPPER**

1 Inserir na anilha no orifício na posição indicada 2 Montar a ponta no ripper 3 Colocar a cavilha no orifício da ponta 4 Use uma chave Allen (hex) ou un soquete HEX para ligar a cavilha (verificar o tamanho da chave no quadro à direita) 5 O mecanismo de fixação permite que o encaixe da borracha se comprima, rode e bloqueie a peça com uma simples rotação de 90° 6 Cada trava vêm acompanhado de um tampão para evitar a entrada de sujeidade nas extremidades. Inserir tampão.

**Desmontagem** repita os passos na ordem inversa.

SOCKET HEX		PART NUMBER			
<b>M13</b>	1/2"	HL2-R300	<b>M10</b>	3/8"	
<b>M13</b>	1/2"	HL2-R350	<b>M10</b>	3/8"	
<b>M17</b>	11/16"	HL2-R450	<b>M14</b>	9/16"	
<b>M22</b>	7/8"	HL2-R500	<b>M18</b>	11/16"	
<b>M24</b>	15/16"	HL2-R550	<b>M21</b>	13/16"	

### OEM Cross Refs (WHEN USING FUTURA TOOTH)

L	L	Ø	Ø				SIZE
mm	in	mm	in				
92	3,62"	20,5	0,81"	<b>FCR300HP</b>	9J-6583	1U-2405	<b>R300</b>
120	4,72"	20,5	0,81"	<b>FCR350HP</b>	8E-6358	1U-2405	<b>R350</b>
135	5,31"	26,0	1,02"	<b>FCR450HP</b>	6Y-3394	8E-4743	<b>R450</b>
153	6,02"	33,0	1,30"	<b>FCR500HP</b>	6Y-3909, 6Y-1204	4T-4707, 6Y-1202	<b>R500</b>
170	6,69"	37,5	1,48"	<b>FCR550HP</b>	8E-2229, 9N-4245	8E-2230, 6Y-1205	<b>R550</b>

**Esco**

DIRECT  
REPLACEMENT  
PARTS FOR

PIEZAS DE  
REEMPLAZO  
DIRECTO PARA

# Esco

## Ripper Components Componentes Ripper

**Bold part number,  
product available**  
*Other part numbers  
please consult*

**Referencia en negrita  
producto disponible**  
*Otras referencias  
consúltenos*

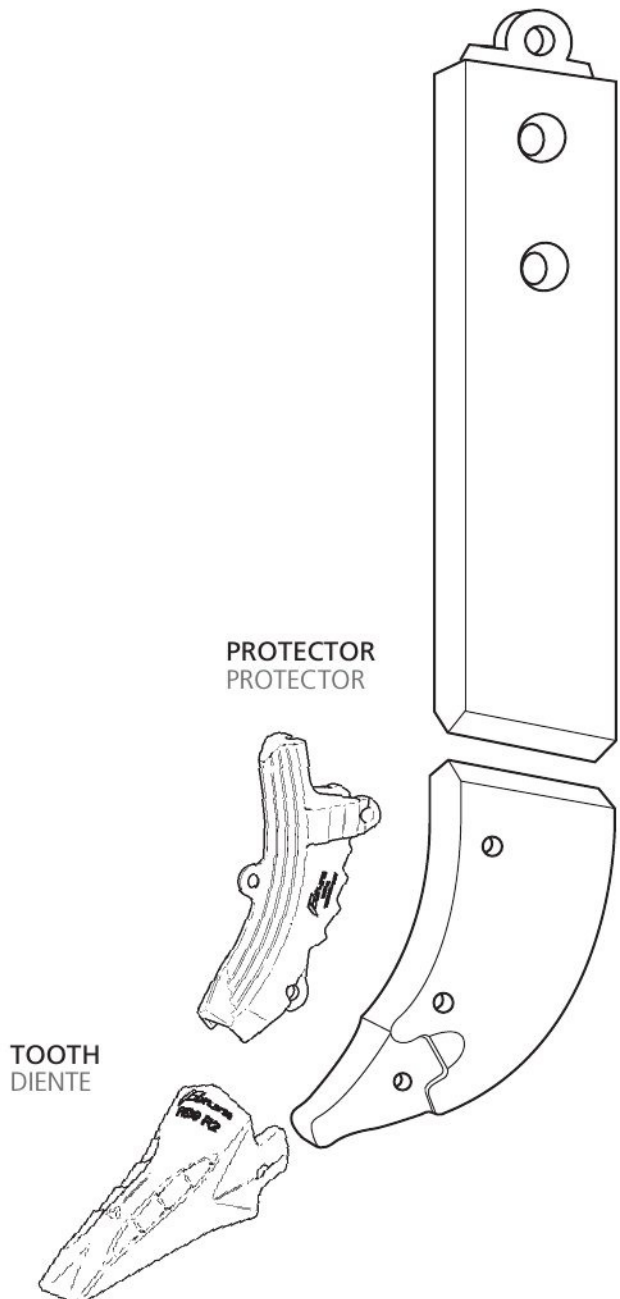

		Power HP Potencia CV	
			
-	<b>FE22 R2</b> 22-R10	30-100	<b>22</b>
-	<b>FE25 R2</b> 25-R12	100-160	<b>25</b>
-	<b>FE35 R2</b> 35-RH1A4	160-300	<b>35</b>
<b>FE39 RPT</b> 39-RHSL	<b>FE39 R2</b> 39-R17E 39-RH17E 39-RH18A	300-500	<b>39</b>

**Esco**

**Ripper Protector** Protector de Ripper

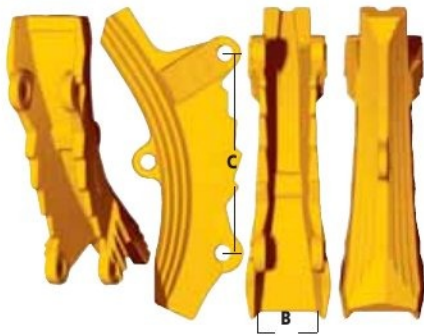

mm.		mm.		mm.		mm.		mm.	
B	C	KG	FE39 RPT	39-SPH	39-SPH	39-SPH	39-RWNS1A	300-500	
90	88	392	39-RHSL	39-SRH	39-SRH	39-SRH			
3,54"	3,46"	15,43"	NAI						
			NAI						

**R2 Ripper Teeth** Diente de Ripper



\*Includes Adaptation Kit  
\*Incluye Kit Adaptación

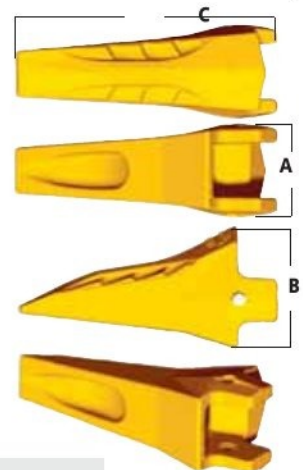

mm.			Current System / Sistema Actual		Old System / Sistema Antiguo			mm.
A	B	C	KG	Current System / Sistema Actual	Old System / Sistema Antiguo	Old System / Sistema Antiguo	Old System / Sistema Antiguo	
86	98	273	4,00	<b>FE22 R2</b> 22-R10	22-RPG	22-RBG	-	<b>22</b>
3,39"	3,86"	10,75"	8,82					
101	106	307	6,00	<b>FE25 R2</b> 25-R12	25-RPG	25-RBG	-	<b>25</b>
3,98"	4,17"	12,09"	13,23					
129	146	407	14,30	<b>FE35 R2*</b> 35-RH14A	35-RPG	49-SR	● 35-RPG	35-RBG <b>35</b>
5,08"	5,75"	16,02"	31,53					
154	214	458	24,90	<b>FE39 R2*</b> 39-R17E 39-RH17E 39-RH18A	49RP-39RPH	49-SR	● 39-RPG	39-RBG <b>39</b>
6,06"	8,43"	18,03"	54,89					

\*Mounts the two systems  
\*Permite montar los dos sistemas:

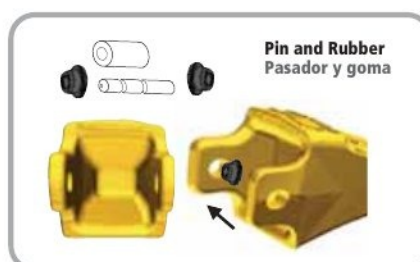
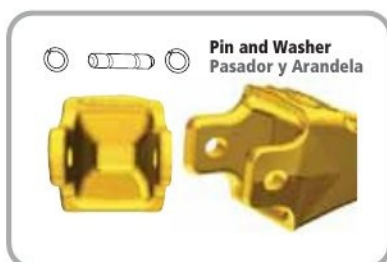



**Pin & Washer Pasador y Arandela**

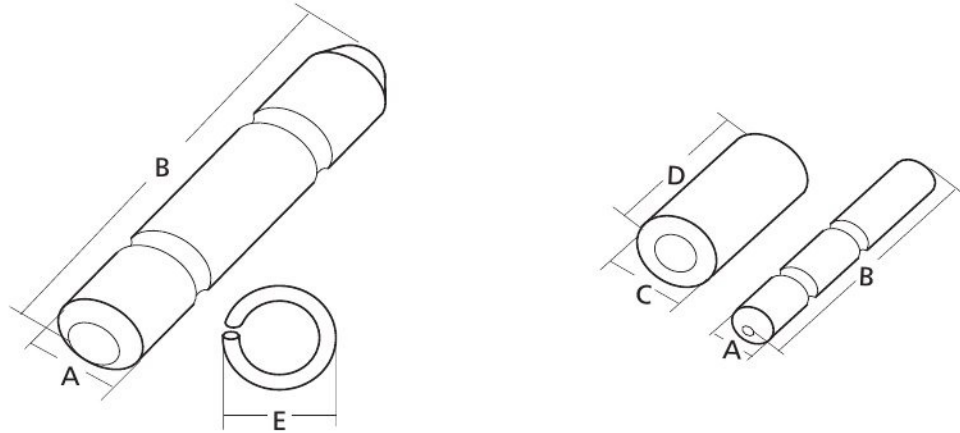

mm.										
A	B	C	D	E						
12,7 0,50"	82 3,23"	20,6 0,81"	56 2,20"	-	-	-	-	<b>22-RPG</b>	<b>22-RBG</b>	<b>22</b>
12,7 0,50"	92 3,62"	20,6 0,81"	64 2,52"	-	-	-	-	<b>25-RPG</b>	<b>25-RBG</b>	<b>25</b>
12,7 0,50"	130 5,12"	20,6 0,81"	84 3,31"	-	-	-	-	<b>35-RPG</b>	<b>35-RBG</b>	<b>35</b>
22,2 0,87"	127 5,00"	-	-	32,6 1,28"	<b>35-RPH</b>	<b>49-SR</b>	-	-	-	<b>35</b>
12,7 0,50"	140 5,51"	20,6 0,81"	84 3,31"	-	-	-	-	<b>39-RPG</b>	<b>39-RBG</b>	<b>39</b>
22,2 0,87"	151 5,94"	-	-	32,6 1,28"	<b>49RP-39RPH</b>	<b>49-SR</b>	-	-	-	<b>39</b>
30 1,18"	133 5,24"	-	-	40,5 1,59"	<b>39-SPH</b>	<b>39-SRH</b>	-	-	-	<b>39</b>

**Esco**

**Komatsu**

DIRECT  
REPLACEMENT  
PARTS FOR

PIEZAS DE  
REEMPLAZO  
DIRECTO PARA

# Komatsu

## Ripper Components Componentes Ripper

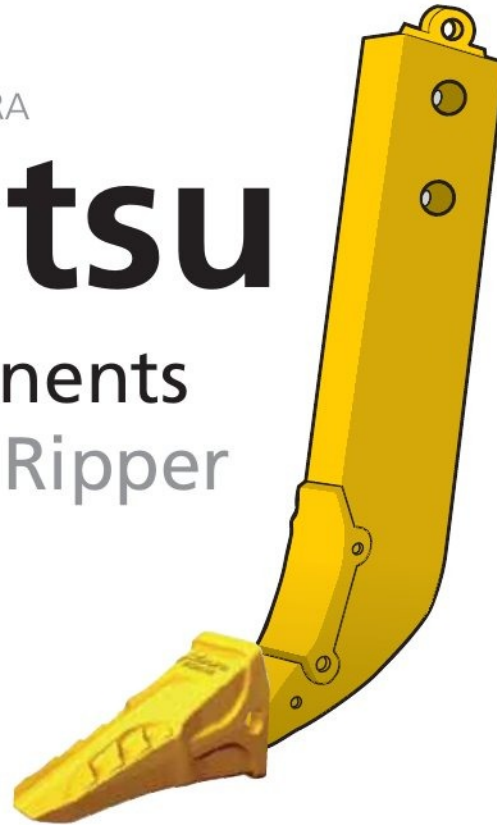

**Bold part number,  
available product**  
Other part numbers  
please consult

**Referencia en negrita  
producto disponible**  
Otras referencias  
consúltenos

### Ripper Teeth Diente Ripper

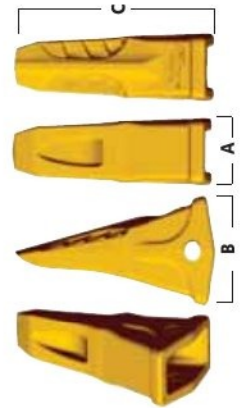
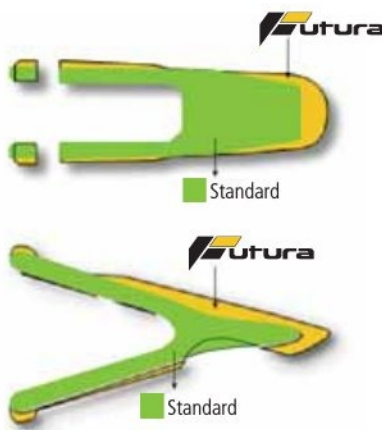

mm.					OEM					
A	B	C								
129 5,08"	185 7,28"	356 14,02"	16,30 35,93	<b>FK155 R2</b>	<b>175-78-31230</b> <b>175-78-31232</b>	175-78-34131 175-78-34141	09244-02508	D85-18, D85-21, D135A-1 D135A-2, D150A-1, D155A-1, D155A-2, D155AX-3	<b>R155</b>	
133 5,24"	215 8,46"	394 15,51"	20,70 45,63	<b>FK355 R2</b>	<b>195-78-21331</b> <b>195-78-21333</b>	195-78-29130 195-78-29140	09244-02508	D275A-2 D355A-3 D455A-1	<b>R355</b>	
144 5,67"	230 9,06"	463 18,23"	30,00 66,14	<b>FK375 R2</b>	<b>195-78-71320</b> <b>195-78-71330</b>	195-78-71340 195-78-71350	195-78-71360	D375A-1 D375A-2	<b>R375</b>	
163 6,42"	266 10,47"	476 18,74"	39,00 85,98	<b>FK475 R2</b>	198-78-21420 198-78-21380	<b>198-78-21350</b> <b>198-78-21340</b>	198-78-21410	D475A-1 D475A-2	<b>R475</b>	

**Komatsu**

**Ripper Fasteners Pasadores Ripper**

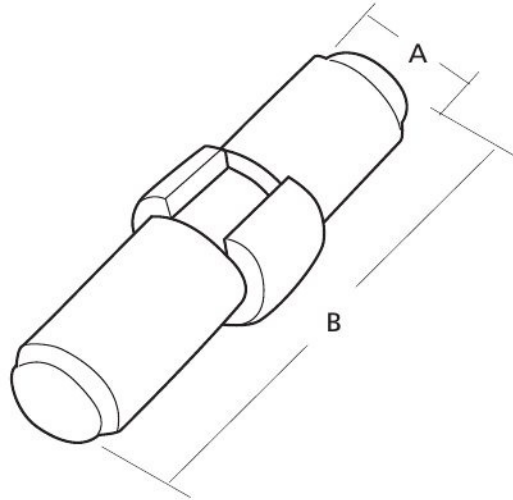

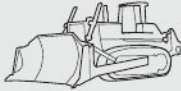
mm.		Ref. BYG	OEM	
A	B			
25 0,98"	97 3,82"	<b>09244-02496</b>	205-70-19610 205-70-69130	D40/D45, D40/D41, D50/D53-16 D50/D53-17, D66S  D60/D65-7 D60/D65-8, D65-12, D75A-1 D75S-3, D75S-5, D85E-SS-2A  D85-18, D85-21, D135A-1, D135A-2 D150A-1, D155A-1, D155A-2, D155AX-3 D275A-2, D355A-3 D455A-1 D375A-1
25 0,98"	109 4,29"	<b>175-78-21740</b>	09244-02508	
30 1,18"	145 5,71"	<b>09244-03036</b>	198-79-11320 A03-78-11730 426-847-1130	D455A-1, D475A-1, D375A-1, D375A-2
30 1,18"	113 4,45"	<b>195-78-71360</b>	-	D375A-1 D375A-2
-	-	198-78-21410	-	D475A-2
-	-	-	-	D475A-1, D475A-2
35 1,38"	185 7,28"	<b>19M-78-11370</b>	19M-78-11371	D575 A-2